

Effect of Problem Solving Method on Science Process Skills and Academic Achievement

Elvan İNCE AKA¹ , Ezgi GÜVEN¹, Mustafa AYDOĞDU²

¹ Research Asst., Gazi University, Gazi Education Faculty, Dept. of Primary Science Education, Ankara-TURKEY

² Prof.Dr., Gazi University, Gazi Education Faculty, Dept. of Primary Science Education, Ankara-TURKEY

Received: 13.04.2009

Revised: 29.04.2010

Accepted: 15.07.2010

The original language of the article is English (v.7, n.4, December 2010, pp.13-25)

ABSTRACT

The aim of the study was to investigate effect of problem solving method on science-process skills and academic achievement. The sample of the research is consisted of 86 3rd class teacher candidates who attended science teaching programme of Gazi Education Faculty. In this study quasi-experimental design which was pre-test/post-test control group was implemented. While experimental group (41 students) was taught problem solving method, control group (45 students) was taught traditional teaching methods in this study. Science process skills test and electric unit achievement test were administered to both groups before and after the instruction as a pre and post test. Results of study reveal that there is no significant difference between experimental and control groups students' pre science process skills and pre achievement test scores. Another result of study displays that experimental group students have higher mean scores than control group students in post science process skills and post achievement test.

Key Words: Problem Solving Method; Science Process Skills; Achievement.

INTRODUCTION

Nowadays, the rapid changes in science and technology have affected the education systems. Individuals, who comprehend these developments and changes and notice their own tasks, are needed in the continuous changing world (Şaşan, 2002). At the moment, individuals have hoped to produce the knowledge besides finding the existent knowledge. As a result of these rapid changes, the education systems need to be modified in such a way that they can enable the students to learn the ways to reach the knowledge, to improve the skills of decision-making and to solve problems. The new comprehension that aims to making a



contribution to this change process should be structured in line with the purpose of an approach that supports and improves the individual's active involvement in life.

In addition, individuals have already made the correct decision and solved the problems by taking into account the value that the knowledge bears and the experiences (Yaşar, 1998; Erbil, et al., 2004).

So, the basic goal of our science education system is bringing in skills to get information instead of transferring to literal at the present day in the information age. One of the widest purposes of science education reformation is to train up students who are interested in science actively (Lorsbach & Tobin, 1992). In addition, this system aims to increase students' academic achievement. This situation is possible for the upper-level mental skills and science process skills. The other possibility of this situation provides that understanding by learning rather than memorization, solving problem which is related to new situation and some skills which are related to the scientific method (Kaptan, 1999). Developing and enhancing ability of problem-solving and science-process skills of students have long been important objectives of science education (NRC, 1996).

In science courses, instead of giving ready prepared information, teaching students to learn how to learn, make comments, getting them to understand and apply the information are needed. Furthermore, making them gain skills of problem solving and behaviors and helping them to gain a habit of scientific thinking should be taught. Therefore, it is needed to improve students' skills of problem solving (Altunçekiç, Yaman & Koray, 2005).

Students encounter a lot of problems in their lives and they try to find particular ways to solve these problems. Problem is the condition of the effort spent on gaining some tasks and needing various equipments in gaining these tasks. Problem solving is an activity which needs not only information of the subject field but also using appropriate methods. Problem solving, interest, being curious and willing are the basic elements that simplify learning. They provide developing students' ability to use the theoretical information in daily life and solving the problems they face, guiding them for studies, and increasing their interest (Sarıbiyık, Altunçekiç & Yaman, 2004).

So, it is important for students to be prepared for the future by facing real problems in their learning environment and producing appropriate solutions to these problems (AAAS, 1993; Gallagher, 1997; Walker & Lofton, 2003; Chin & Chia, 2004). Therefore, appropriate methods must be chosen to realize this situation in the learning environment. One of these methods is problem solving method.

Problem solving method is a learning model which centers on student, develops active learning, skills of problem-solving and field knowledge, and it is based on understanding and problem solving (Major et al., 2000; Malinowski & Johnson, 2001).

Problem solving method includes process of scientific thought. Problem solving method shows thought in advanced level when this method is described as a scientific process in terms of finding, inquiry, critical thought (Kemertaş, 2001). Ability of problem-solving is generally viewed as the ability to reason analytically, to think critically and to create productively, which all involves quantitative, communicative, manual and critical-response skills (AAAS, 1993).

In recent years, it can be seen that problem solving method is widely used in science teaching. Problem solving method is the center of the science curriculum, which would affect the whole curriculum. This method which provides the group working is student-centered. Problem solving method makes a teacher a guide for regulatory problems as a stimulus for learning, provides development of the student's problem-solving skills and new information to learn self. In addition, this method is based on the real-life problems. So, it provides information and to remember concepts more easily in the case of any problems encountered in

the future. For example, some researchers argue for the value of learning process skills in order to develop expertisation in problem solving (Ango, 2002).

Thus, using problem solving method should be beneficial for increasing students' academic achievement and developing science process skills in our education system.

Science process skills are the thinking skills that we use to process information, to think about solving problems, and formulate conclusions (Tan & Temiz, 2003). These skills are the skills which individuals in the society must have to be a scientifically literate. In addition, creative thinking and science process skills are very important for the individuals in recognizing and solving the existent problems in their daily lives (Aktamış & Ergin, 2007). Science process skills consist of both basic science process skills and integrated science process skills. There are 12 skills outlined in the syllabus such as measurement, namely observation, classification and using numbers, time and spatial relationships, making inference, prediction, controlling variables, communication, interpreting data, defining operationally, formulating hypotheses and experimentation. The first seven skills are named as basic science process skills, while the last five skills are named as integrated science process skills (M.S.R., 2004).

There are many process skills included in the conduct of the scientific research. So, it is not appropriate to teach all process skills at once or to teach all of them at all age levels of students. The concept of the science curriculum provides an appropriate guide for the teaching and studying of process skills (Ango, 2002).

Developing and enhancing science process skills and ability of problem solving of students have long been important objectives of education system (AAAS, 1993). Experiences for school students in their guided study of science should include experiences which promote process skills, such as observing, measuring, classifying and predicting. These skills are critical for the development of a worthwhile and fruitful understanding by students of scientific concepts and propositions. These experiences are critical for achieving to expertise in the meaningful using of scientific procedures for problem solving and for applying scientific understanding to one's own life (Ango, 2002).

In this process the teacher is the major impediment for the process of developing scientific skills. Because of necessity, teachers play a crucial role in assisting students to acquire scientific process skills. There is a prima facie case that teachers need to acquire the skills of science in order to be in a position to foster the same understanding of those skills in their students. Appropriate selections of science process skills can be taught and studied in the early years of primary school. The young students can be given the opportunity to observe, handle things and explore the environment (Ango, 2002).

The importance of the role of process and problem solving skills in the teaching and studying of science is widely acknowledged by experts in the field. So, we think that method of problem solving should be effective for increasing individual's success and developing science process skills.

The basic purpose of this study is to investigate the effect of problem solving method on science process skills and academic achievement.

METHODOLOGY

a) Research Design and Participants

Designs which aim to determine causal connection between the variables are experimental design (Büyüköztürk, 2001). In this study a quasi-experimental design was implemented to a pre-test/post-test control group. Quasi-experimental designs do not include the usage of random assignment (Fraenkel & Wallen, 2003). In this study, while experimental

group was taught problem solving method, control group was taught traditional teaching methods (Table 1).

The participants consisted of 86 students (41 students in the experimental group, 45 students in the control group). The groups received science instruction for the same length of time as they were taught by the same researchers.

Throughout the 8 weeks, while the electric unit subjects were taught to the students in the experimental group by using unit problems and experiments, the students in the controlling group were taught through the methods such as the direct telling and asking-answering (traditional teaching methods).

Before the application, an explanation covering the instruction method was given to participants. The first applied method was the problem solving. The method, a proven successful strategy in teaching students to solve electric unit' problems, includes the following five steps:

1. Read what problems are given,
2. Write what problems are given,
3. Write what is being asked
4. Plan to solve the problems
5. Solve the problems.

In the application of this method, the teacher gave information about problem solving by using the first lesson. Students were required to read the problems and then solve the given electric unit' problems by using this method. At the last lesson, the solutions of the problems were discussed together. Researchers gave the problem for example below.

Problem:

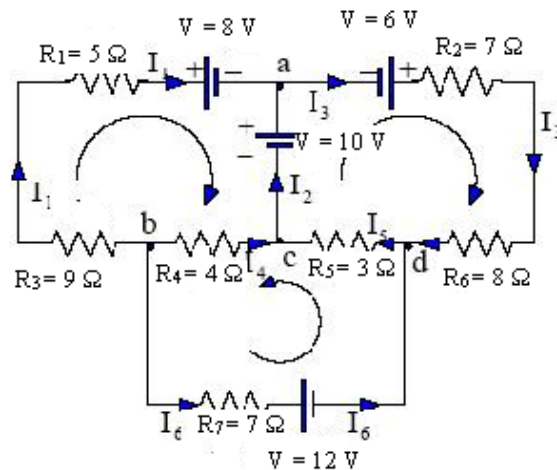

What are the $I_1, I_2, I_3, I_4, I_5, I_6$ current values in the many loop electric circuit figures?

Then, students read the problem. And they wrote the problem in their own notebook. Then, students noticed that what is asked in the problem. At last, students planned to solve problem and solved the problem in their own notebook.

In the control group, students were taught the methods of the direct telling and asking-answering. Because of the time spent with explanations of the methods and solution of the sample problems in the experimental group, to equalize the duration of the lessons, additional problems were given to the control group. Given problems which are related to the electric unit' subjects being taught in the class were chosen by researchers. When teaching the electric unit' subjects, researchers used only the direct telling and asking-answering methods of problem solving.

Science process skills test and electric unit achievement test were administered to both groups before the instruction as a pre-test. Both groups studied the same science content over an 8 week period. The instruments were administered to both groups after the instruction as a post-test.

Table 1. *Experimental design of research*

Groups	Pre- Tests	Teaching Method	Post-Tests
Experiment	Science Process Skills, Achievement	Problem Solving	Science Process Skills, Achievement
Control	Science Process Skills, Achievement	Traditional	Science Process Skills, Achievement

b) Sample

The sample of the research is consisted of 86 3rd class candidate teachers who attended Gazi Education Faculty of Science Teaching Programme on the first term of 2007–2008 education years.

c) Population

The population of the study is consisted of candidate teachers who attended Gazi University Gazi Education Faculty on the first term of 2007–2008 education years.

d) Instruments

In this study the following instruments were used to gather data:

1. Science Process Skills Test: Science process skills test consisting 30 multiple-choice items. In the positive statements, the articles marked as true were given 1 point and the false ones were given 0 point. This scale was prepared by researchers and it was developed according to steps of the science process skills in science education. In order to check the reliability coefficient of the test it was administered to 107 teacher candidates in Gazi University. KR–20 was used for analyzes of reliability and the reliability value of the test was found as $KR-20 = .76$. For the validity of the test, the opinions of experts were taken. In addition, analyze of factor was made for validity of the structure.

2. Electric Unit Achievement Test: Electric unit achievement test’s purpose was to measure students’ achievement levels and pre-knowledge. For many years, Bloom’s taxonomy of educational objectives has received wide recognition, and it has been used in many science fields. Bloom identified three major domains of intended learning outcomes: the cognitive domain of knowledge, the affective domain or attitudes and the psychomotor domain of manipulative skills. These categories provide the suitable test for realizing the study’s aim.

Achievement test was prepared for learning steps of cognitive domain. In this study achievement test was prepared by researchers and test is consisted of 25 questions. Some sample items of electric unit achievement test were given in the below of this paper.

In order to check the reliability coefficient of the test it was administered to 107 candidate teachers in Gazi University. KR–20 was used for analyzes of reliability and the reliability value of the test was found as $KR-20 = .80$. In addition, ITEMAN programme was implemented. Questions’ difficulty degree was found as $(pj) = .487$ and means item discrimination index as $(tjx) = .476$. The opinion of an expert was sought for extent validity.

Distribution of achievement test questions was given in table 2 according to steps of cognitive domain.

Table 2. *Distribution of steps of cognitive domain according to questions*

Steps of cognitive domain	Number of question
Knowledge	2,3,16,20
Comprehension	1,5,7,10,14,21
Application	8,11,15,22
Analysis	4,12,23,18
Synthesis	9,13,17,24
Evaluation	6,25,19

e) Analyze of Data

SPSS programme was used in the statistical analysis of data. Independent sample test was used to compare data which was collected from the study. In order to prove homogeneity of each group, dependent variables were compared before treatment by using independent sample t-test as well as post test results of experimental and control group was compared with independent sample t-test. Results of data were assessment as .05 of the significance level.

FINDINGS

Findings which are obtained from analyzes were given in tables.

Table 3. *Independent sample t-test results of pre test science process skills scores*

Group	N	M	S.D.	t	P
Experiment	41	74,20	4,256	1,361	,177
Control	45	72,98	4,037		

As it can be seen in table 3, there is no significant difference between experimental (M= 74,20) and control group (M= 72,98) students' scores of pre-science process skills test ($p > .05$, $t = 1,361$).

Table 4. *Independent sample t-test results of pre test achievement scores*

Group	N	M	S.D.	t	P
Experiment	41	69,00	5,979	1,260	,211
Control	45	67,49	5,137		

Data presented in table 4 shows that the mean of pre test achievement scores of students is $M = 69,00$ in experimental group. Control group students mean score is $M = 67,49$. As it can be seen from the table 4, there is no significant difference between experimental and control group students' pre test achievement scores ($p > .05$, $t = 1,260$).

Table 5. *Independent sample t-test results of post test science process skills scores*

Group	N	M	S.D.	t	P
Experiment	41	80,12	3,565	4,161	,000
Control	45	75,53	6,185		

As it can be seen in table 5, there is significant difference between experimental (M= 80,12) and control group (M= 75,53) students' post science process skills test scores ($p < .05$, $t = 4,161$).

Table 6. *Independent sample t-test results of post test achievement scores*

Group	N	M	S.D.	t	P
Experiment	41	78,29	4,627	3,902	,000
Control	45	73,89	5,718		

Data presented in table 6 shows that the mean of post test scores of students is $M = 78,29$ in experimental group. Control group students mean score is $M = 73,89$. As it can be seen from the table 6, there is significant difference between experimental and control group students' post achievement test scores ($p < .05$, $t = 3,902$).

DISCUSSION and CONCLUSION

In this study in which the effects of the application of the problem solving method in the unit of "Electric" in 3rd class teacher candidates' academic achievement and changes of science process skills were examined and following results were obtained.

Statistical results reveal that there is no significant difference among experimental and control groups' scores of pre science process skills tests (Table 3). Also, there is no significant difference between experimental and control group pre achievement test scores (Table 4). These situations are compatible with the purpose of determining the effectiveness of instructional method that is used.

As a result of this study, there is a significant difference in scores of post science process skills test between experimental and control group students (Table V). Because problem solving method makes students obtain some skills like research, discovery, scientific thinking. In addition, this method teaches gathering data, shows ways of solution for problems, improves analyzes of data and provides anticipation of research and experiments results (Lee et al., 2000; Kalaycı, 2001; Aksoy, 2002).

It is observed in the studies about the subject that problem-solving methods developed students' scientific process skills (Açıkyıldız, 2004; Tavukcu, 2006). Teaching methods used in the study of many students has been seen to be effective on the scientific process skills in many domestic and abroad studies (Owens, 1997; Turpin, 2000; Krystyniak, 2001; DiSimoni, 2002; Huziak, 2003; Özdemir, 2004; Bozkurt, 2005; Tatar, 2006, Kanlı, 2007). In studies, the method which is running emerged that individuals within the environment realize the problems to identify, resolve and ensure that the individuals in this process have scientific process skills (Aktamış & Ergin, 2007).

The final result of study there is a significant difference in scores of the post achievement test between experimental and control group students (Table VI). There is an increase in both experimental and control groups students in the scores of the post test achievement after treatment. This result proves that both problem solving and traditional teaching methods have positive effect on students' achievement. But problem solving method is more effective than traditional teaching methods. This situation may have been appeared that problem solving method is student centered and develops student's self-reliance, cognitive learning and scientific learning (Saban, 2000; Aksoy, 2002).

Many studies from Turkey and abroad were investigated and it was found that results of these studies show parallelism with results of our study (Chang, 2001a; 2001b; Kan, 2003; Şenocak, 2005).

Problem-solving method used in mathematics courses for the success of primary school students and its impact on attitudes toward mathematics were examined by Yıldızlar (1998). In the study, while problem-solving method was used in experimental group, traditional teaching methods were used in the control group. According to the findings of the research results, students of the experimental group success and attitudes toward mathematics increased significantly.

Methods of teaching and methods to manage the relationship between mastery were examined (Nietfeld & Schraw, 2002). Students were divided into two in experimental and control groups. Problem-solving method was used for the students in the experimental group. The head of research and eventually the test which includes mathematical probability problems was applied to students as a pre-test and post-test. After a week at the end of the application permanence test was applied to both of the groups. At the conclusion of the study, the significant differences were found between the permanence tests and experimental and control group students' post-test mean scores. Experimental group students who were applied problem solving methods have test scores higher than the other group.

Straight narrative and problem solving methods were examined for the effects of persistence and the level of access for students by Kaptan, Aslan and Atmaca (2002). Model which has not been synchronized with the control group constitutes the experimental research design. "The atmosphere at the Natural Exposure" issue; while experimental group was processed by the problem-solving method, control group was processed by using the method of straight narrative. Courses were conducted by researchers. At the end of research, a significant difference between the two groups has not been found in the aspect of the level of access.

The seventh grade students in elementary social studies course "17 and 18 Century Ottoman Empire "and" 19 and 20th Century Ottoman Empire" units using the method of problem solving for the effect of student achievement was investigated by Kan (2003). In the research, in the total 86 students as 42 of them in the control and 44 of them in the experimental group attended and multiple-choice test of 40 questions were used. Pre test-post test research design was used and at the end of the research, a significant difference was found between scores of the experimental and control group students' post-test.

In the light of the findings, the researcher determined that the problem solving method is more influential than the traditional teaching approach.

In the classrooms where problem solving method is used, learners take much more responsibility for their own learning; they have become independent learners who can continue to learn in their whole lifetime. This method turns the student from passive recipient of information to the active one, free self learner and problem solver and it slides the emphasis of educational programmes from teaching to learning (Çuhadaroğlu et. al., 2003).

When the aims of science education are examined, it is also seen that the problem solving method is appropriate for realization of science education aims (Tobin, 1986; AAAS, 1993). And many science educators considering this method have increasingly started to apply this method in science education (Treagust & Peterson, 1998; Gallagher et al., 1999; Greenwald, 2000; Yuzhi, 2003; Şenocak, 2005; Kılıç, 2006).

The basic learning which pupils achieve from these initial experiences can be used as a basis for building a more extensive understanding of science process and problem solving skills in the later education life. So, this research has a critically importance in terms of science education related to science process skills, achievement and problem solving method.

REFERENCE

- AAAS, (1993). *American association for the advancement of science. Benchmarks for science literacy*. New York: Oxford University Press.
- Açıkyıldız, M. (2004). *Investigation of effectiveness of problem-based learning at physical chemistry laboratory experiments*. Unpublished Master Thesis. Atatürk University, Erzurum.
- Aksoy, N. (2002). *Sınıf yönetimi (Classroom management)*. Ankara: Pegem Press.
- Aktamış, H. & Ergin, Ö. (2007). Bilimsel süreç becerileri ile bilimsel yaratıcılık arasındaki ilişkinin belirlenmesi (Investigating the relationship between science process skills and scientific creativity). *Hacettepe Üniversitesi Eğitim Fakültesi Dergisi*, 33, 11–23.
- Altunçekiç, A., Yaman, S. & Koray, Ö. (2005). Öğretmen adaylarının öz-yeterlik inanç düzeyleri ve problem çözme becerileri üzerine bir araştırma (Kastamonu ili örneđi) (A study on levels of self-efficacy beliefs and problem solving skills of teacher candidates) *Kastamonu Education Journal*, 13(1), 93–102.
- Ango, M.L. (2002). Mastery of science process skills and their effective use in the teaching of science: an educology of science education in the Nigerian context. *International Journal of Educology*, 16, (1), 11-30.
- Bozkurt, O. (2005). *Effects of teaching 6th grade secondary school science lesson on students' attitudes, achievements and science process skills by using Dunn and Dunn learning styles model*. Unpublished Doctoral Thesis, Gazi University, Ankara.
- Büyüköztürk, Ş. (2001). *Deneyisel desenler: öntest-sontest kontrol grubu desen ve veri analizi (Experimental designs: pre test-post test control group design and data analyze)*. Ankara: Pegem Press.
- Chang, C. Y. (2001a). Comparing the impacts of a problem-based computer-assisted instruction and the direct-interactive teaching method on student science achievement. *Journal of Science Education and Technology*, 10, 147–153.
- Chang, C. Y. (2001b). A problem-solving based computer-assisted tutorial for the earth sciences. *Journal of Computer Assisted Learning*, 17, 263–274.
- Chin, C. & Chia, L. G. (2004). Problem-based learning: using students' questions to drive knowledge construction, *Science Education*, 88(5), 707–727.
- Çuhadarođlu, F., Karaduman, A., Önderođlu, S., Karademir, N. & Şekerel, B. (2003). *Probleme dayalı öğrenme oturumları uygulama rehberi (Problem based learning session application guide)*. Hacettepe Üniversitesi Tıp Eğitimi ve Bilişimi Anabilim Dalı, Ankara.(Accessed from: http://www.medinfo.hacettepe.edu.tr/tebad/docs/kitap/PDO_2003.pdf , (05.03. 2009)
- DiSimoni, K. C. (2002). *Using writing as a vehicle to promote and develop scientific concepts and process skills in fourth-grade students*. Ph.D. dissertation, Fordham University, United States. ProQuest Digital Dissertations database, (Publication No. AAT 3040393, 02.03.2010).
- Erbil, O., Demirezen, S., Erdoğan, A., Terzi, Ü., Erođlu, H., ve İbiş, M. (2004). Öğrenci merkezli eğitim uygulama modeli (Student-centered education practice model). *İktisat Kongresi Eğitimde Uygulamalar Bölümü Tebliđi, İzmir*.
- Fraenkel, R. J. & Wallen, E. N. (2003). *How to design and evaluate research in education*. New York: Mc Graw Hill.
- Gallagher, S.A. (1997). Problem based learning: Where did it come from, what does it do, and where is it going? *Journal for the Education of the Gifted*, 20(4), 332–362.
- Gallagher, S.A., Stephien, W.J., Sher, B.T. & Workman, D. (1999). Implementing problem-based learning in science classrooms. *School Science and Mathematics*, 95(3), 136–146.
- Greenwald, N.L. (2000). Learning from problems. *The Science Teacher*, 67(4), 28–32.

- Huziak, T. L. (2003) *Verbal and social interaction patterns among elementary students during self-guided "I Wonder Projects"*. Ph.D. dissertation, The Ohio State University, United States. ProQuest Digital Dissertations Database, (Publication No. AAT 3124085, 02.03.2010).
- Kalaycı, N. (2001). *Sosyal bilgilerde problem çözüme ve uygulama (Problem solving and application in social sciences)*. Ankara: Gazi Press.
- Kan, Ç. (2003). *The effect of the problem solving method on to student success in primary school second rank social studies lesson*. Unpublished Master Thesis, Gazi University. Ankara.
- Kanlı, U. (2007). *The effects of a laboratory based on the 7e model with verification laboratory approach on students? development of science process skills and conceptual achievement*. Unpublished Doctoral Thesis, Gazi University, Ankara.
- Kaptan, F. (1999). *Fen bilgisi öğretimi (Teaching of science)*. İstanbul: Milli Eğitim Press.
- Kaptan, F., Aslan, F. & Atmaca, S. (2002). Problem çözüme yönteminin kalıcılığa ve öğrencilerin erişü düzeyine etkisine yönelik deneysel bir çalışma (An experimental study towards effect of problem solving method on achievement and permanence). V. *Ulusal Fen Bilimleri ve Matematik Eğitim Kongresi*, Ankara.
- Kemertaş, İ. (2001). *Uygulamalı genel öğretim yöntemleri (Practical general teaching methods)*. İstanbul: Birsen Press.
- Kılıç, G.B. (2006). *İlköğretim bilim öğretimi (Primary science teaching)*, İstanbul: Morpa Press.
- Krystyniak, R. A. (2001) *The effect of participation in an extended inquiry project on general chemistry student laboratory interactions, confidence, and process skills*. Ph.D. dissertation, University of Northern Colorado, United States. ProQuest Digital Dissertations Database, (Publication No. AAT 3006597, 02.03.2010).
- Lee, L. K. W., Tan, L. L., Goh, N. K., Chia, L. S., & Chin, C. (2000). Science teachers and problem solving in elementary schools in Singapore. *Research in Science & Technological Education*, 18(1), 113-126.
- Lorsbach, A. & Tobin, K. (1992). *Constructivism as a referent for science teaching*. In Lawrenz, F. Research matters to the science teacher. Monograph number 5. Kansas State University: National Association for Research in Science Teaching.
- M.S.R. (2004). *In proceedings of the first international workshop on mining software repositories*. Edinburgh, United Kingdom.
- Major, C., H., Baden, M., S. & Mackinnon, M., (2000). Issues in problem based learning: a message from guest editors. *Journal on Excellence in College Teaching*, 11 (2), 1-14.
- Malinowski, J. & Johnson, M. (2001). Navigating the acvtive learning swamp. *Journal of College Science Teaching*, 31(3).
- Nietfeld, J., & Schraw, G. (2002). The effect of knowledge and strategy training on monitoring accuracy. *Journal of Educational Research*, 95, 131-142.
- N.R.C. (1996). *National research council. national science education standards*. Washington D.C.: National Academy Press.
- Owens, K. D. (1997) *The effect of instruction by a professional scientist on the acquisition of integrated process skills and the science-related attitudes of eighth-grade students*. Ed.D. dissertation, The University of Southern Mississippi, United States. ProQuest Digital Dissertations Database, (Publication No. AAT 9806498, 02.03.2010).
- Özdemir, M. (2004). *The effects of cooperative learning based on constructivist approach in primary social studies*. Unpublished Master Thesis, Karaelmas University, Zonguldak.
- Saban, A. (2000). *Öğrenme öğretim süreci yeni teori ve yaklaşımlar (Learning teaching process new theory and approach)*. Ankara: Nobel Press.

- Sarıbıyık, S., Altunçekiç, A. & Yaman, S. (2004). Öğretmen adaylarının fen bilgisi laboratuvarı dersine yönelik ilgi düzeylerinin ve problem çözme becerilerinin incelenmesi üzerine bir araştırma (A research study on laboratory science courses and problem solving skills and interest level of teacher candidates) *XIII. Ulusal Eğitim Bilimleri Kurultayı, Malatya*.
- Şaşan, H. H. (2002). Yapılandırmacı öğrenme (Constructivist learning) *Yaşadıkça Eğitim Dergisi*, 74 (75), 49–52.
- Şenocak, E. (2005). *A study on the impact of problem based learning approach to teaching gas state of matter*. Unpublished Doctoral Thesis, Atatürk University, Erzurum.
- Tan, M. & Temiz, B., K. (2003). Fen öğretiminde bilimsel süreç becerilerinin yeri ve önemi (Place and importance of science process skills in science teaching). *Pamukkale Üniversitesi Eğitim Fakültesi Dergisi*, 1(13). 89-101.
- Tatar, N. (2006). *The effect of inquiry-based learning approaches in the education of science in primary school on the science process skills, academic achievement and attitude*. Unpublished Doctoral Thesis, Gazi University, Ankara.
- Tavukcu, K. (2006). *Effect Of the problem based learning on learning products in science lesson*. Unpublished Master Thesis, Karaelmas University, Zonguldak.
- Tobin, K. (1986). Student task: Involvement and achievement in process-oriented science activities. *Science Education*, 70, 61–72.
- Treagust, D.F. & Peterson, R.F. (1998). Learning to teach primary science trough problem based learning. *Science Education*, 82(2), 215–237.
- Turpin, T. J. (2000). *A study of the effects of an integrated, activity-based science curriculum on student achievement, science process skills, and science attitudes*. Ed.D. dissertation, University of Louisiana at Monroe, United States. ProQuest Digital Dissertations Database, (Publication No. AAT 9993727, 02.03.2010).
- Walker, J.T. & Lofton, S.P. (2003). Effect of a problem based learning curriculum on students' perceptions of self directed learning. *Issues in Educational Research*, 13.
- Yaşar, Ş. (1998). Yapılandırmacı kuram ve öğrenme –öğretme süreci (Constructivist theory and learning-teaching process) *Anadolu Üniversitesi Eğitim Fakültesi Dergisi*, 8 (1), 68–75.
- Yıldızlar, M. (1999). *The Effect of the teaching problem solving behaviours on the achievement at 1. 2. 3. grade levels students of primary schools*. Unpublished Doctoral Thesis, Hacettepe University, Ankara.
- Yuzhi, W. (2003). Using problem–based learning and teaching analytical chemistry. *The China Papers.*, 18-32.

Appendix 1

Sample Items of Science Process Skills Test

3. A group of students thought to connect five lamps parallel to each other. If you think the parallel circuit connected to the first lamp fails, this situation how affects the brightness of the other lamps in the electric circuit?
- Increases the brightness of the other lamps
 - Decrease the brightness of the other lamps
 - Does not change the brightness of the other lamps
 - Lamp which is closest to broken lamp brighter lights
 - Lamp which is closest to broken lamp turn
9. A farmer has a 100 acre farm. Farmer wants to grow wheat with maximum efficiency in this field. Sizce bu çiftçi daha verimli hasat elde edebilmek için aşağıdaki yollardan hangisini izlemelidir? Which way must be chosen to grow more efficient harvesting by the farmer?
- Farmer should use more wheat germ
 - Farmer should be prefer quality wheat seed
 - Farmer must use greater amounts of chemical fertilizers
 - Farmer should use more than the required amount of water
 - Farmer should expand the planting area
13. Ali, Çađla, Damla and Murat have competition which is named whose lamp will be more brightness. For this purpose, the necessary materials were investigated. 4 separate cups were used. Ali added pure water to first cup. Çađla added dilute HCl solution to second cup. Damla added dilute NaOH solution to third cup. Finally added Murat added saline water fourth cup. Then they have established consisting of the circuit with conductor cables, electrodes, batteries and switches. Electrodes of prepared circuit were immersed respectively pure water, acid solution, base solution, and saline solution by them. Then they switched off. In this case, whose lamp does not burn?
- Ali's lamp
 - Çađla's lamp
 - Murat's lamp
 - Damla's lamp
 - None of the lamp does not burn
27. Ceren wanted to make cakes for the guests. Ceren put required materials for cake in a suitable cap and she clap this material. Then she basted cake mold and she pour dough to cake mold. She set oven temperature to required degree. Then she put cake to oven. What should Ceren make in order to cook cake well?
- Ceren should heat oven- a period of time before she put cake to oven
 - Ceren should open cover of the oven time and time again during the cooking
 - Ceren should increase temperature degree of the oven
 - Ceren should use more flour to make cake dough
 - Ceren should add baking powder to dough

Appendix 2

Sample Items of Electric Unit Achievement Test

7. X sphere which is shown in the figure is positive electrically charged. This sphere is closing up to A- B bar which is neutral and conductive. In this time, How is electric charge distribution of A-B points of sphere and bar?

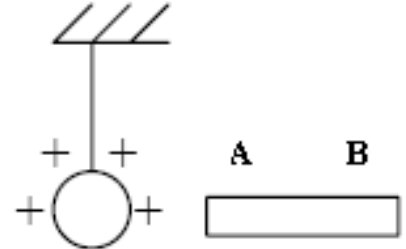

X **A** **B**

- A. + - +
- B. neutral + -
- C. + neutral +
- D. - + -
- E. + - neutral

17. The following three circuits are installed with identical generators. How is compare of brightness of identical X – Y- Z lamb?

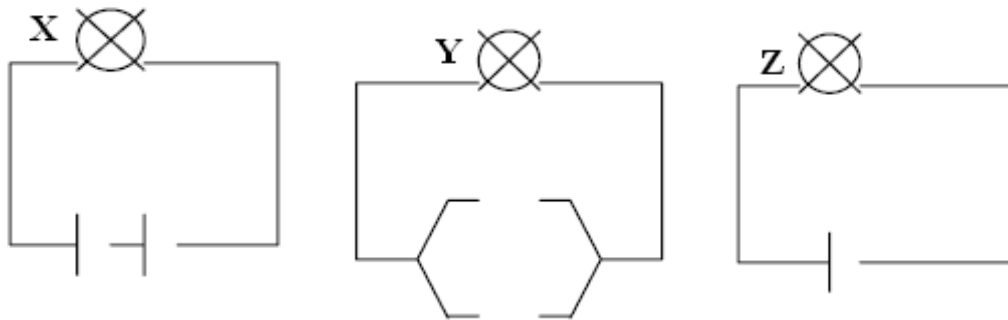

- A. $Y > X > Z$
- B. $X > Z > Y$
- C. $X = Z > Y$
- D. $X = Y = Z$
- E. $Y > Z > X$

23. An electrically powered car's total energy of the 2.10^5 J are provided by a 12 volt battery. What happens given the engine's current, if the car's electric motor power draws 8 kW?

- A. 584 A B. 6,66 A C. 66600 A D. 5,84 A E. 326 A